

TL8X-XXXX

Encapsulated, horizontal mount, common mode line filter

- Fully encapsulated
- Inductance balanced within 1% (1-4 & 2-3)
- Dielectric strength, 1500Vrms between windings
- Temperature class, 130 °C
- Nominal voltage, 250Vrms
- Inductance test level, 10kHz @ 10mV
- RoHS compliant per 2002/95/EC

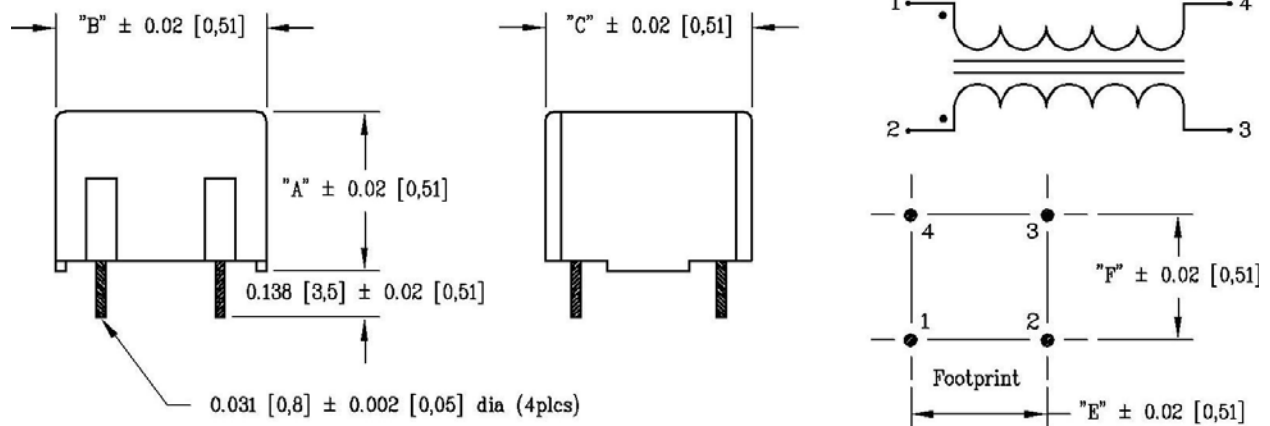

P/N	"A" " [mm]	"B" " [mm]	"C" " [mm]	"E" " [mm]	"F" " [mm]
TL81-XXXX	0.49 [12,5]	0.67 [17,0]	0.71 [18,0]	0.39 [10,0]	0.59 [15,0]
TL82-XXXX	0.61 [15,5]	0.89 [22,5]	0.95 [24,0]	0.49 [12,5]	0.79 [20,0]
TL83-XXXX	0.69 [17,5]	1.06 [27,0]	1.18 [30,0]	0.59 [15,0]	0.98 [25,0]
TL84-XXXX	0.69 [17,5]	1.26 [32,0]	1.30 [33,0]	0.79 [20,0]	1.18 [30,0]
TL85-XXXX	0.81 [20,5]	1.46 [37,0]	1.61 [41,0]	0.79 [20,0]	1.38 [35,0]

Rev B, 12/09

TL81-XXXX Dash #	“L” ± 30% (mH)	“P” rated (Amps)
-0000	400 uH	2.60
-0001	1.2	2.00
-0002	1.8	1.70
-0003	2.7	1.50
-0004	3.3	1.50
-0005	3.9	1.30
-0006	6.8	1.20
-0007	10	0.70
-0008	15	0.50
-0009	18	0.45
-0010	27	0.40
-0011	39	0.40
-0012	47	0.30

TL82-XXXX Dash #	“L” ± 30% (mH)	“P” rated (Amps)
-0013	400 uH	3.0
-0014	1.2	2.8
-0015	1.8	2.5
-0016	2.7	2.5
-0017	3.3	2.5
-0018	3.9	1.5
-0019	6.8	1.5
-0020	10	1.2
-0021	15	0.8
-0022	18	0.8
-0023	27	0.8
-0024	39	0.5
-0025	47	0.5

TL83-XXXX Dash #	“L” ± 30% (mH)	“P” rated (Amps)
-0026	400 uH	3.8
-0027	1.2	3.2
-0028	1.8	3.0
-0029	2.7	2.8
-0030	3.3	2.8
-0031	3.9	2.5
-0032	6.8	2.0
-0033	10	1.6
-0034	15	1.2
-0035	18	1.2
-0036	27	1.0
-0037	39	0.9
-0038	47	0.8

TL84-XXXX Dash #	“L” ± 30% (mH)	“I” rated (Amps)
-0039	400 uH	4.5
-0040	1.2	4.0
-0041	1.8	3.5
-0042	2.7	3.5
-0043	3.3	3.0
-0044	3.9	3.0
-0045	6.8	2.5
-0046	10	2.0
-0047	15	1.8
-0048	18	1.8
-0049	27	1.5
-0050	39	1.4
-0051	47	1.3

TL85-XXXX Dash #	“L” ± 30% (mH)	“I” rated (Amps)
-0052	400 uH	7.0
-0053	1.2	6.0
-0054	1.8	5.0
-0055	2.7	4.0
-0056	3.3	4.0
-0057	3.9	3.5
-0058	6.8	3.0
-0059	10	2.5
-0060	15	2.0
-0061	18	1.8
-0062	27	1.8
-0063	39	1.5
-0064	47	1.5